

State Show

Small Fry & Non Pro Walk/ Trot Horsemanship

Show Date: 08/31/2017

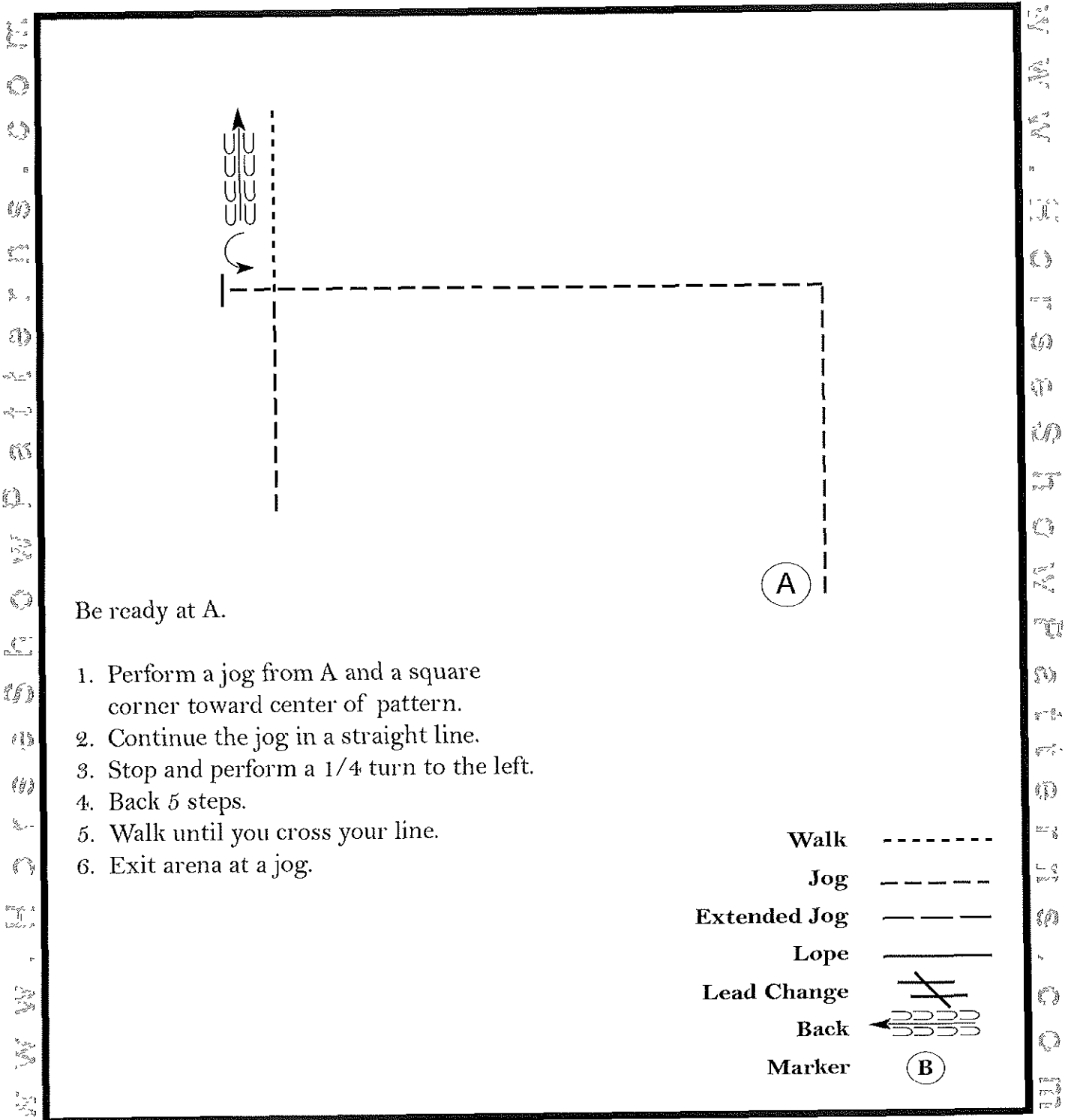

[WH/WT-104]

Pattern Provided by:

The Judges

State Show

Rookie & L1 Youth & Amateur Horsemanship

Show Date: 08/31/2017

W. W. W. H. O. S. H. O. W. P. A. T. T. E. R. N. S. . C. O. M.

Be ready at A.

1. Perform a jog from A and a square corner toward center of pattern.
2. Lope a left lead circle.
3. Close the circle and continue loping on the left lead in a straight line.
4. Stop and perform a 1/4 turn to the left.
5. Back 5 steps.
6. Walk until you cross your line.
7. Exit arena at a jog.

Walk -----
Jog - - - - -
Extended Jog - - - - -
Lope _____
Lead Change
Back
Marker (B)

[WH/1-104]

Pattern Provided by:

The Judges

State Show

Amateur, Amateur Select Horsemanship

Show Date: 08/31/2017

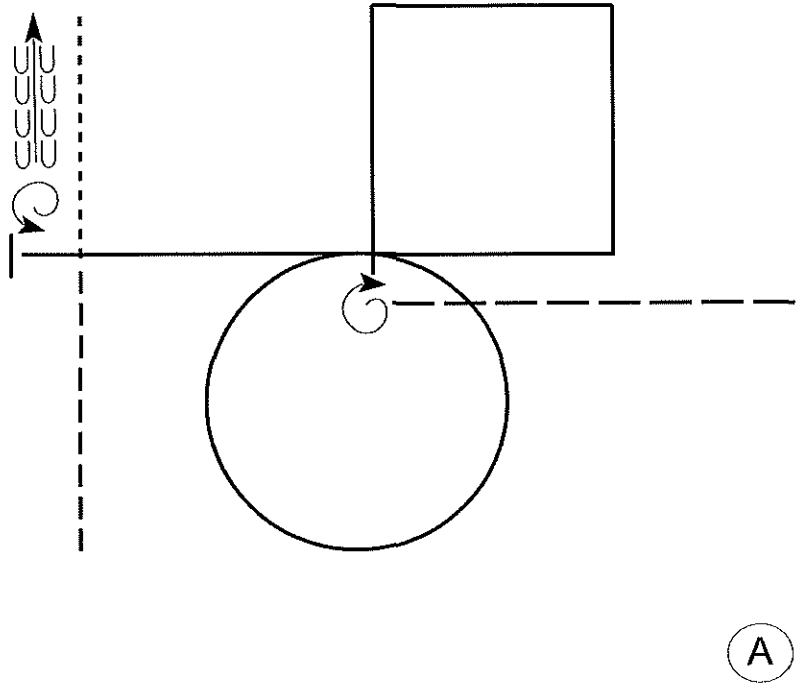

Be ready at A.

1. Perform an extended jog from A and a square corner toward center of pattern.
2. Stop in center and perform a 1 1/4 turn right.
3. Lope a right lead square.
4. Change leads at center and lope a left lead circle.
5. Close the circle and continue loping on the left lead in a straight line.
6. Stop and perform a 1 1/4 turn to the left.
7. Back 5 steps.
8. Walk until you cross your line.
9. Exit arena at a jog.

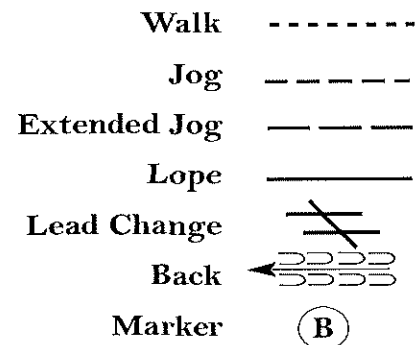

[WH/3-104]

Pattern Provided by:

The Judges

State Show

Yth 13 & under, 14- 18 Horsemanship

Show Date: 08/31/2017

Horse Show Patterns.com

Horse Show Patterns.com

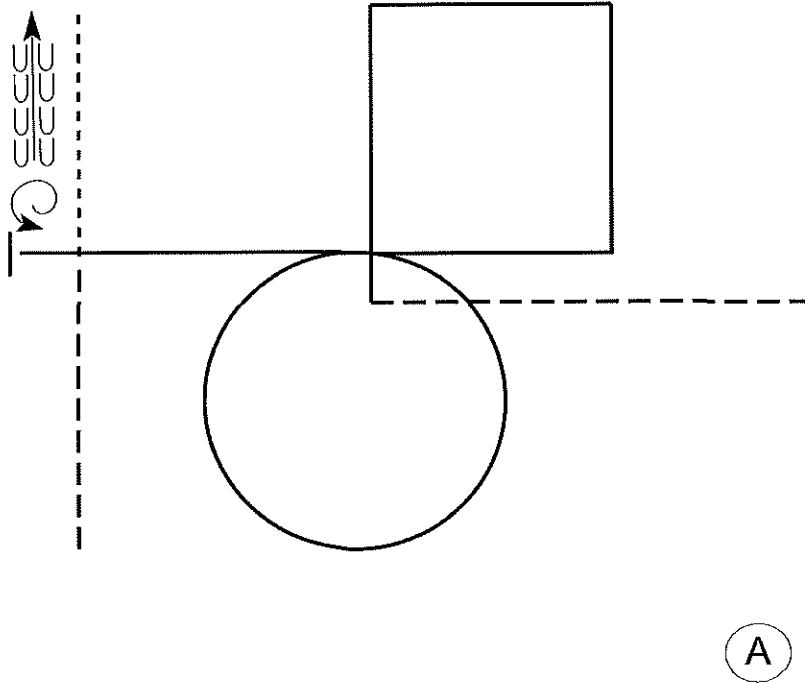

Be ready at A.

1. Perform a jog from A and a square corner toward center of pattern.
2. Make a square corner right at center.
3. Lope a right lead square.
4. Change leads at center and lope a left lead circle.
5. Close the circle and continue loping on the left lead in a straight line.
6. Stop and perform a 1 1/4 turn to the left.
7. Back 5 steps.
8. Walk until you cross your line.
9. Exit arena at a jog.

Walk	-----
Jog	- - - - -
Extended Jog	— — — — —
Lope	—————
Lead Change	
Back	
Marker	(B)

[WH/2-104]

Pattern Provided by:
The Judges

State Show

Small Fry & Non Pro Walk/ Trot Equitation

Show Date: 08/31/2017

www.horsepatterns.com

www.horsepatterns.com

Be ready before A.

1. Walk to A.
2. Trot on the right diagonal to center of pattern and in a half circle around B.
3. Continue to trot on the right diagonal from B to C.
4. Walk around C.
5. Trot on the left diagonal to B.
6. Halt at B and back approximately one horse length. Walk straight away.

Follow the instructions of your ring steward.

Walk	-----
Trot	- - - - -
Extended Trot	=====
Canter	—————
Leg Yield	
Lead Change	—/—
Back	←←←←←
Marker	(B)
Sidepass	← ←
Hand Gallop	—————

[HSE/WT-60]

Pattern Provided by:
The Judges

State Show

Rookie & L1 Youth, Rookie & L1 Amateur Eq

Show Date: 08/31/2017

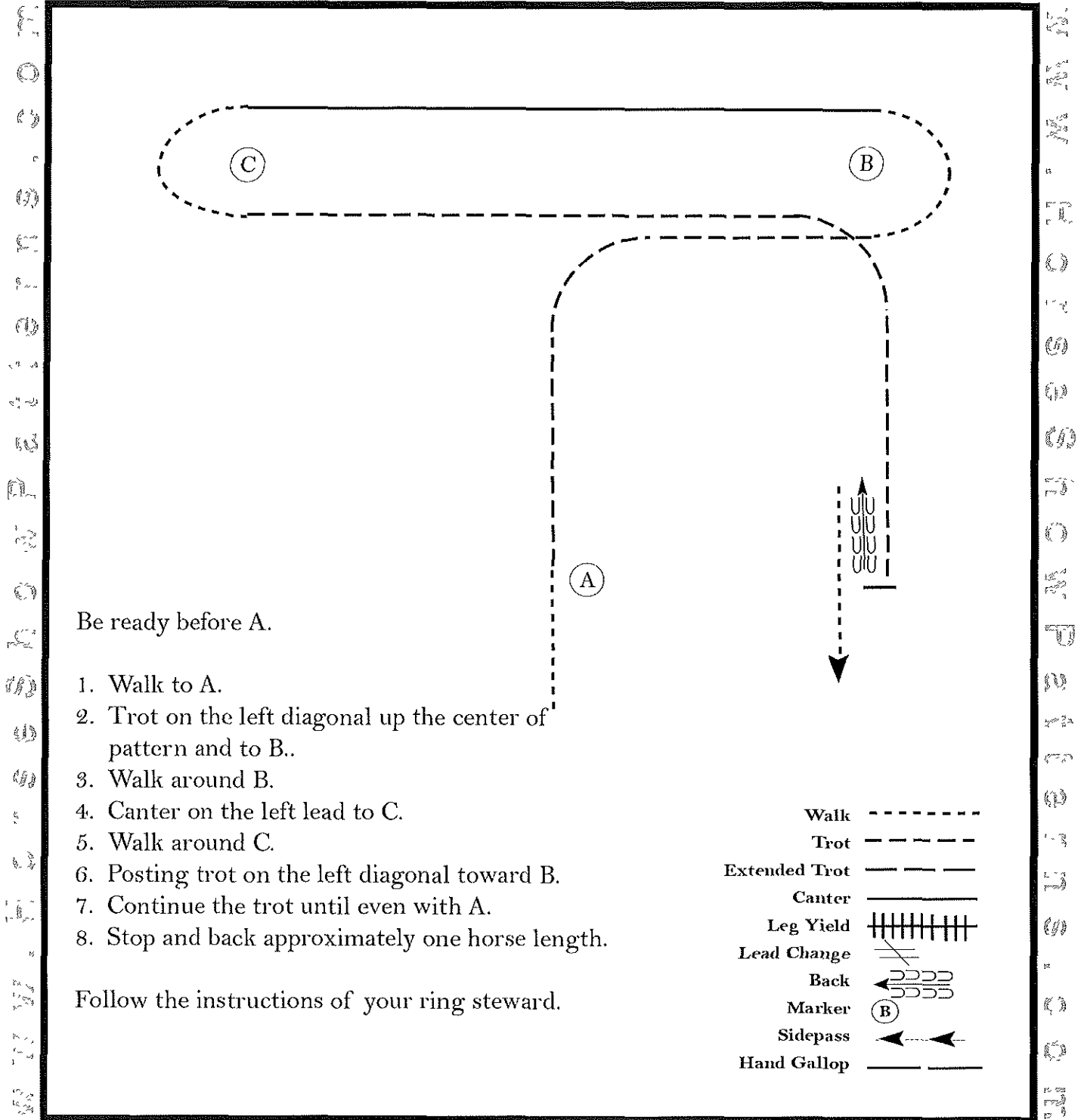

[HSE/1-71]

Pattern Provided by:
The Judges

State Show

Amateur/ Amateur Select Equitation

Show Date: 08/31/2017

Horse Show Patterns.com

Horse Show Patterns.com

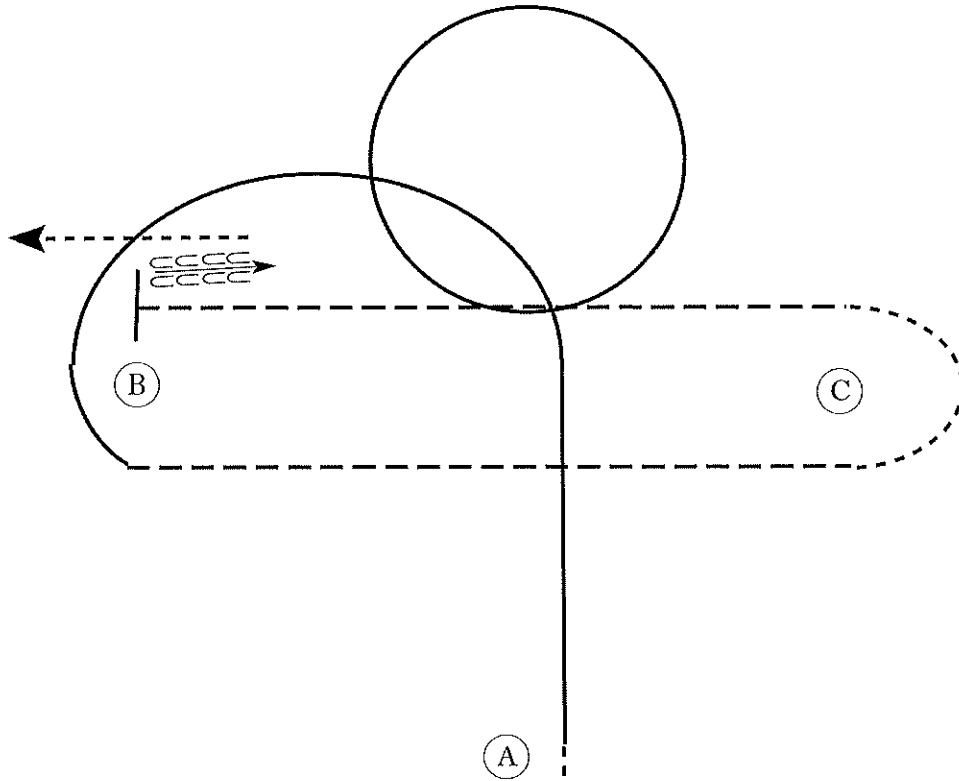

Be ready before A.

1. Walk to A.
2. Canter on the left lead to center of pattern and in a half circle around B.
3. Trot on the right diagonal from B to C.
4. Walk around C.
5. Trot on the left diagonal halfway to B.
6. Canter a right lead circle.
7. Sitting trot until even with B.
8. Halt at B and back approximately one horse length. Walk straight away.

Follow the instructions of your ring steward.

Walk	-----
Trot	- - - - -
Extended Trot	=====
Canter	—————
Leg Yield	
Lead Change	↗ ↘
Back	← ← ← ← ←
Marker	(B)
Sidepass	← - - - - ← - - - -
Hand Gallop	—————

[HSE/3-60]

Pattern Provided by:
The Judges

State Show

14- 18, 13 & under Equitation

Show Date: 08/31/2017

Be ready before A.

1. Walk to A.
2. Canter on the left lead to center of pattern and in a half circle around B.
3. Trot on the right diagonal from B to C.
4. Walk around C.
5. Trot on the left diagonal halfway to B.
6. Continue to trot a circle to the right.
7. Sitting trot until even with B.
8. Halt at B and back approximately one horse length. Walk straight away.

Follow the instructions of your ring steward.

Walk	-----
Trot	- - - - -
Extended Trot	— — — — —
Canter	—————
Leg Yield	
Lead Change	— / —
Back	← 2222 5555
Marker	(B)
Sidepass	← - - - - ←
Hand Gallop	— — — — —

[HSE/2-60]

Pattern Provided by:
The Judges

State Show

L1, L1 Nov Am, L1 Nov Yth western riding

Show Date: 08/31/2017

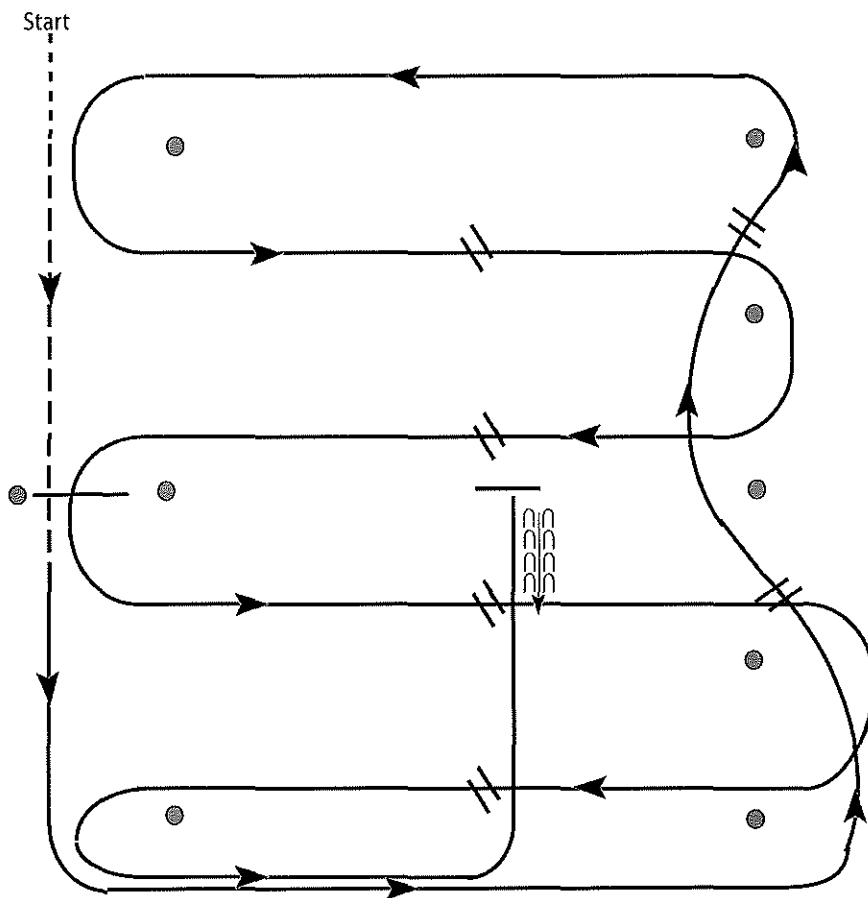

1. Walk at least 15' & jog over log.
2. Transition to left lead and lope around end.
3. First line change.
4. Second line change. Lope around end of arena
5. First crossing change.
6. Second crossing change.
7. Lope over log.
8. Third crossing change.
9. Fourth crossing change.
10. Lope up the center, stop and back.

[WR/GP-1]

Pattern Provided by:

The Judges

State Show

Jr, Am, Am Select, Youth, Sr Western Riding

Show Date: 08/31/2017

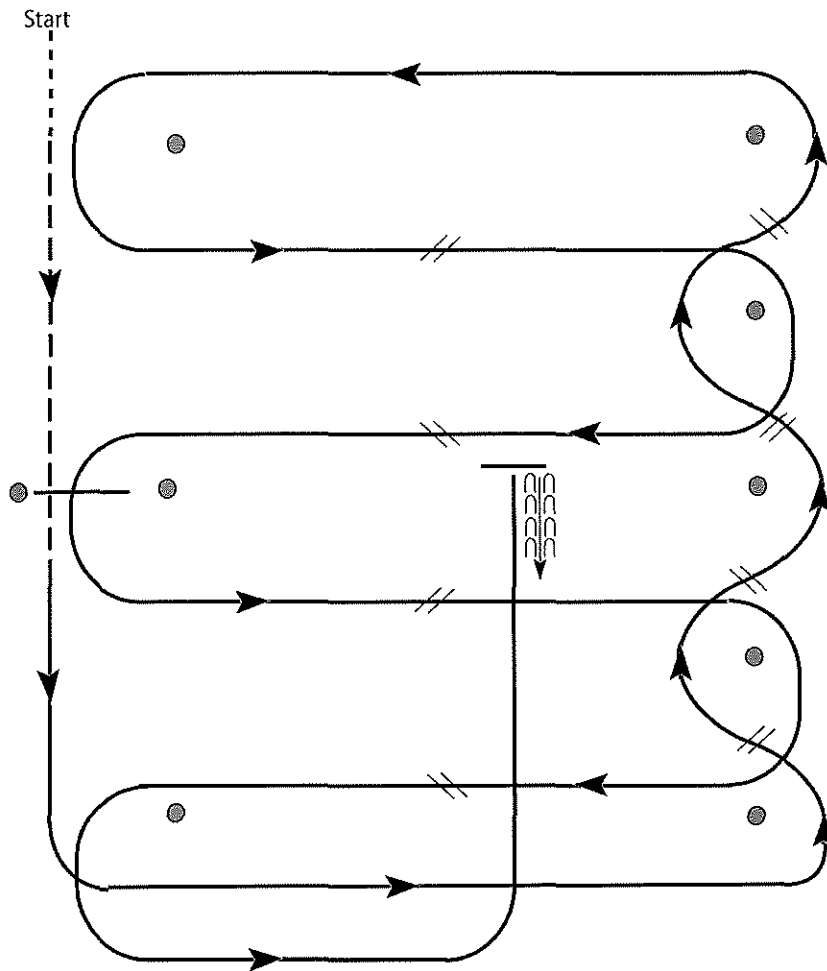

1. Walk and jog over log.
2. Transition to lope and lope around end.
3. First line change.
4. Second line change.
5. Third line change.
6. Fourth line change and lope around the end of the arena.
7. First crossing change.
8. Second crossing change.
9. Lope over log
10. Third crossing change.
11. Fourth crossing change.
12. Lope up the center, stop and back.

[WR/OP-1]

Pattern Provided by:

The Judges

State Show

Amateur, Youth, Open Ranch Riding

Show Date: 08/31/2017

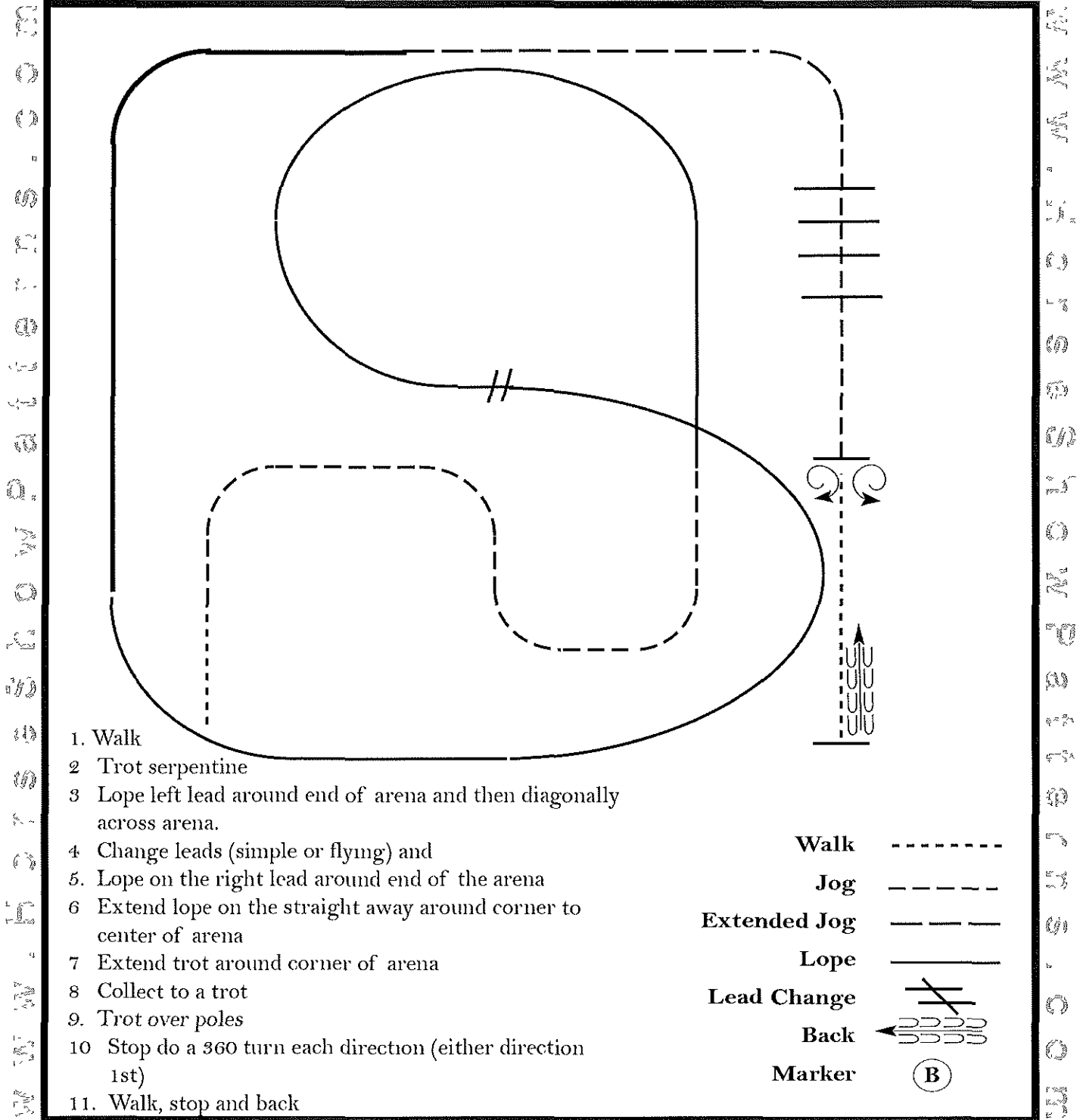

[RR/4]

Pattern Provided by:

The Judges

State Show

Amateur, Yth, Open Reining

Show Date: 08/31/2017

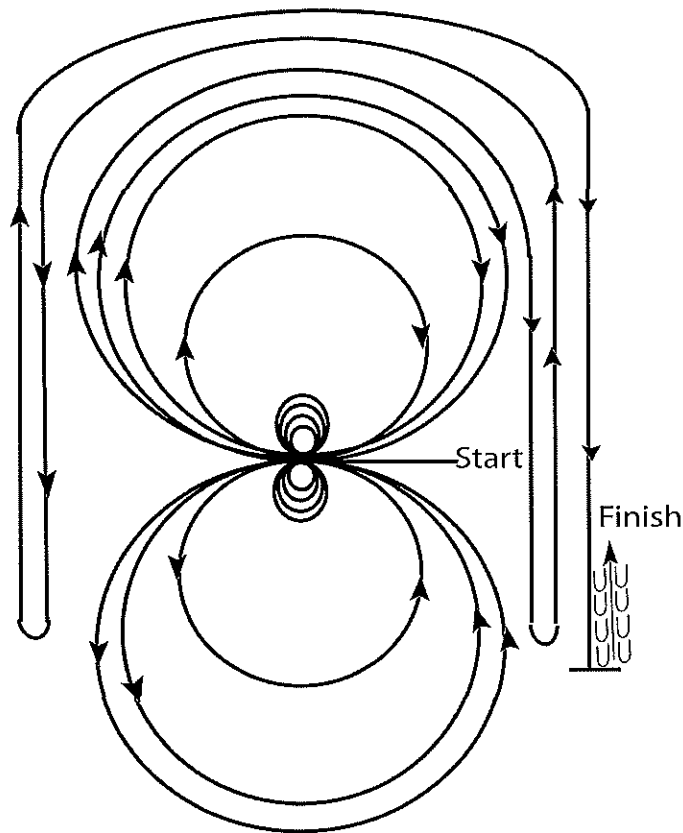

Horses must walk or stop prior to starting pattern Beginning at the center of the arena facing the left wall or fence.

- 1 Complete four spins to the left.
2. Complete four spins to the right. Hesitate.
- 3 Beginning on the right lead, complete three circles to the right. the first circle large and fast, the second circle small and slow; the third circle large and fast Change leads at the center of the arena
- 4 Complete three circles to the left the first circle large and fast, the second circle small and slow; the third circle large and fast. Change leads at the center of the arena.
- 5 Begin a large fast circle to the right but do not close this circle. Run straight down the right side of the arena past the center marker and do a left rollback at least twenty feet (6.09m) from the wall or fence
– no hesitation
- 6 Continue back around the previous circle but do not close this circle. Run down the left side of the arena past the center marker and do a right rollback at least twenty feet (6.09m) from the wall or fence
– no hesitation
7. Continue back around the previous circle but do not close this circle. Run down the right side of the arena past the center marker and do a sliding stop at least twenty feet (6.09m) from the wall or fence Back up at least ten feet (3m) Hesitate to demonstrate completion of the pattern.
Rider may drop bridle to the designated judge

[R/AQHAP-8]

Pattern Provided by:

The Judges